

JVC



MICRO COMPONENT SYSTEM

UX-G50

—Consists of CA-UXG50 and SP-UXG50

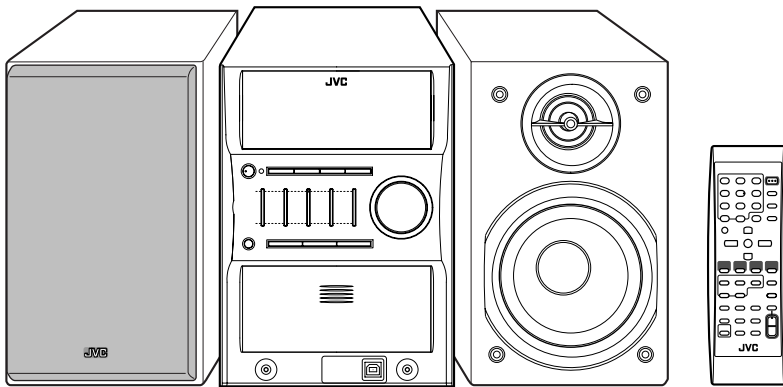

COMPACT
disc
DIGITAL AUDIO

MP3
PLAYBACK

INSTRUCTIONS

For Customer Use:

Enter below the Model No. and Serial No. which are located either on the rear, bottom or side of the cabinet. Retain this information for future reference.

Model No. _____

Serial No. _____

LVT1519-001B

[J]

Warnings, Cautions and Others Mises en garde, précautions et indications diverses

	CAUTION RISK OF ELECTRIC SHOCK DO NOT OPEN	
CAUTION: TO REDUCE THE RISK OF ELECTRIC SHOCK, DO NOT REMOVE COVER (OR BACK). NO USER SERVICEABLE PARTS INSIDE. REFER SERVICING TO QUALIFIED SERVICE PERSONNEL.		



The lightning flash with arrowhead symbol, within an equilateral triangle is intended to alert the user to the presence of uninsulated "dangerous voltage" within the product's enclosure that may be of sufficient magnitude to constitute a risk of electric shock to persons.



The exclamation point within an equilateral triangle is intended to alert the user to the presence of important operating and maintenance (servicing) instructions in the literature accompanying the appliance.

WARNING: TO REDUCE THE RISK OF FIRE OR ELECTRIC SHOCK, DO NOT EXPOSE THIS APPLIANCE TO RAIN OR MOISTURE.

CAUTION

To reduce the risk of electrical shocks, fire, etc.:

- 1 Do not remove screws, covers or cabinet.
- 2 Do not expose this appliance to rain or moisture.

ATTENTION

Afin d'éviter tout risque d'électrocution, d'incendie, etc.:

- 1 Ne pas enlever les vis ni les panneaux et ne pas ouvrir le coffret de l'appareil.
- 2 Ne pas exposer l'appareil à la pluie ni à l'humidité.

CAUTION— (STANDBY/ON) button!

Disconnect the mains plug to shut the power off completely (all lamps and indications go off). When installing the product ensure that the plug is easily accessible. The  button in any position does not disconnect the mains line.

- When the unit is on standby, the STANDBY lamp lights in red.
- When the unit is turned on, the STANDBY lamp goes off.

The power can be remote controlled.

ATTENTION—Touche (STANDBY/ON)!

Deconnectez la fiche secteur pour mettre l'appareil complètement hors tension (tous les témoins et toutes les indications s'éteignent). Lors de l'installation de l'appareil, assurez-vous que la fiche soit facilement accessible. La touche  dans n'importe quelle position ne déconnecte pas l'appareil du secteur.

- Quand l'appareil est en mode d'attente, le témoin STANDBY est allumé en rouge.
- Quand l'appareil est sous tension, le témoin STANDBY s'éteint.

L'alimentation ne peut pas être commandée à distance.

For U.S.A.

This equipment has been tested and found to comply with the limits for a Class B digital device, pursuant to part 15 of the FCC Rules. These limits are designed to provide reasonable protection against harmful interference in a residential installation.

This equipment generates, uses and can radiate radio frequency energy and, if not installed and used in accordance with the instructions, may cause harmful interference to radio communications. However, there is no guarantee that interference will not occur in a particular installation. If this equipment does cause harmful interference to radio or television reception, which can be determined by turning the equipment off and on, the user is encouraged to try to correct the interference by one or more of the following measures:

- Reorient or relocate the receiving antenna.
- Increase the separation between the equipment and receiver.
- Connect the equipment into an outlet on a circuit different from that to which the receiver is connected.
- Consult the dealer or an experienced radio/TV technician for help.

CAUTION

Changes or modifications not approved by JVC could void the user's authority to operate the equipment.

For the main unit:

Declaration of Conformity

Model Number: UX-G50
Trade Name: JVC
Responsible Party: JVC Americas Corp.
Address: 1700 Valley Road, Wayne
New Jersey 07470
Telephone Number: 973-317-5000

This device complies with Part 15 of FCC Rules. Operation is subject to the following two conditions:
(1) This device may not cause harmful interference, and (2) this device must accept any interference received, including interference that may cause undesired operation.

Note to CATV system installer:

This reminder is provided to call the CATV system installer's attention to section 820-40 of the NEC which provides guidelines for proper grounding and, in particular, specifies that the cable ground shall be connected to the grounding system of the building, as close to the point of cable entry as practical.

For Canada/pour le Canada

THIS DIGITAL APPARATUS DOES NOT EXCEED THE CLASS B LIMITS FOR RADIO NOISE EMISSIONS FROM DIGITAL APPARATUS AS SET OUT IN THE INTERFERENCE-CAUSING EQUIPMENT STANDARD ENTITLED "DIGITAL APPARATUS," ICES-003 OF THE DEPARTMENT OF COMMUNICATIONS.

CET APPAREIL NUMERIQUE RESPECTE LES LIMITES DE BRUITS RADIOELECTRIQUES APPLICABLES AUX APPAREILS NUMIRIQUES DE CLASSE B PRESCRITES DANS LA NORME SUR LE MATERIEL BROUILLEUR; "APPAREILS NUMERIQUES", NMB-003 EDICTEE PAR LE MINISTRE DES COMMUNICATIONS.

Caution: Proper Ventilation

To avoid risk of electric shock and fire, and to prevent damage, locate the apparatus as follows:

1. Front: No obstructions and open spacing.
2. Sides/ Top/ Back: No obstructions should be placed in the areas shown by the dimensions below.
3. Bottom: Place on the level surface. Maintain an adequate air path for ventilation by placing on a stand with a height of 10 cm ($3\frac{15}{16}$ " or more).

Attention: Aération correcte

Pour prévenir tout risque de décharge électrique ou d'incendie et éviter toute détérioration, installez l'appareil de la manière suivante:

1. Avant: Bien dégagé de tout objet.
2. Côtés/dessus/dessous: Assurez-vous que rien ne bloque les espaces indiqués sur le schéma ci-dessous.
3. Dessous: Posez l'appareil sur une surface plane et horizontale. Veillez à ce que sa ventilation correcte puisse se faire en le plaçant sur un support d'au moins dix centimètres de hauteur.

Front Face

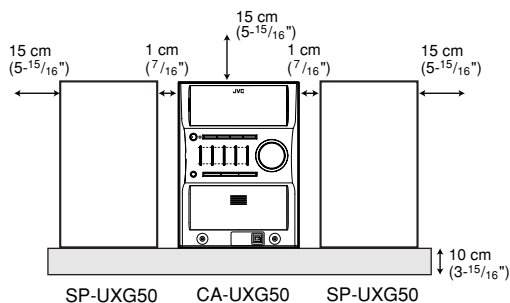

Side Côté

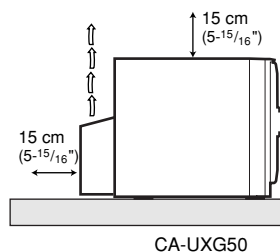

* About the cooling fan

A cooling fan is mounted on the rear panel of the unit to prevent abnormal temperature inside the unit, thus assuring normal operation of the unit. The cooling fan automatically starts rotating to intake external cool air when the volume is increased up to more than a certain level.

* À propos du ventilateur de refroidissement

Un ventilateur de refroidissement se trouve sur le panneau arrière de l'appareil afin d'éviter la création d'une température anormale à l'intérieur de l'appareil et permettre ainsi un fonctionnement normal de l'appareil. Le ventilateur de refroidissement commence à tourner et à aspirer de l'air frais automatiquement quand le volume est augmenté au-dessus d'un certain niveau.

IMPORTANT FOR LASER PRODUCTS / IMPORTANT POUR PRODUITS LASER

1. CLASS 1 LASER PRODUCT
 2. **CAUTION:** Do not open the top cover. There are no user serviceable parts inside the unit; leave all servicing to qualified service personnel.
 3. **CAUTION:** VISIBLE AND / OR INVISIBLE CLASS 1M LASER RADIATION WHEN OPEN. DO NOT STARE INTO BEAM OR VIEW DIRECTLY WITH OPTICAL INSTRUMENTS.
 4. REPRODUCTION OF LABEL: CAUTION LABEL, PLACED INSIDE THE UNIT.
1. PRODUIT LASER CLASSE 1
 2. **ATTENTION:** N'ouvrez pas le couvercle supérieur. Il n'y a aucune pièce réparable par l'utilisateur à l'intérieur de l'appareil; confiez toute réparation à un personnel qualifié.
 3. **ATTENTION:** RAYONNEMENT LASER VISIBLE ET / OU INVISIBLE DE CLASSE 1M UNE FOIS OUVERT. NE PAS FIXER LE FAISCEAU NI REGARDER DIRECTEMENT AVEC DES INSTRUMENTS OPTIQUES.
 4. REPRODUCTION DE L'ÉTIQUETTE: ÉTIQUETTE DE PRÉCAUTION PLACÉE À L'INTERIEUR DE L'APPAREIL.

CAUTION VISIBLE AND/OR INVISIBLE CLASS 1M LASER RADIATION WHEN OPEN. DO NOT STARE INTO BEAM OR VIEW DIRECTLY WITH OPTICAL INSTRUMENTS. (ENG)	VARNING SYNLIIG OCH/ELLER OSYNLIIG LASERSTRÅLNING KLASS 1M, NÄR DENNA DEL ÄR ÖPPNAD. STIRRA EJ IN I STRÅLEN OCH BETRÄKTA EJ STRÅLEN MED OPTISKA INSTRUMENT. (SWE)	AVISO RADIACION LÁSER DE CLASE 1M VISIBLE Y/O INVISIBLE CUANDO ESTA ABIERTO. NO MIRAR FIJAMENTE EL HAZ NI OBSERVAR DIRECTAMENTE CON INSTRUMENTAL ÓPTICO. (ESP)	ADVARSEL SYNLIIG OG/ELLER USYNLIIG KLASSE 1M -LASERSTRÅLING VED ÅBNING. SE IKKE IND I STRÅLEN - HELLER IKKE MED OPTISKE INSTRUMENTER. (DNK)	VARO! ÄVÄRT TAESSÄ OLET ÄLT TIINA NÄKYVÄLLE JÄ/TÄI NÄKYMÄTÖMÄLLE LUOKAN 1M LASERSTRÄLTYLLE. ÄLÄ KATSO SUORAAN SÄTEESEEN TAI TÄRKASTELE SITÄ OPTISEN LAITTEEN LAPI. (FIN)	ATTENTION RAYONNEMENT LASER VISIBLE ET/OU INVISIBLE DE CLASSE 1M UNE FOIS OUVERT. NE PAS FIXER LE FAISCEAU NI REGARDER DIRECTEMENT AVEC DES INSTRUMENTS OPTIQUES. LV44803-001A (FRA)
---	--	--	---	--	---



[European Union only]

Contents

Introduction	2
Precautions	2
How to Read This Manual	3
Getting Started	4
Step 1: Unpack	4
Step 2: Prepare the Remote Control	4
Step 3: Hook Up	5
Before Operating the System	8
Daily Operations—Playback	9
Listening to the Radio	10
Playing Back a Disc	11
Playing Back from the PC	13
Playing Back from other equipment	14
Quick Portable Link (QP Link)	14
Daily Operations	
—Sound & Other Adjustments	15
Adjusting the Volume	15
Adjusting the Sound	15
Changing the Display Brightness—DIMMER	16
Setting the Clock	16
Turning Off the Power Automatically	17
Advanced Disc Operations	18
Programming the Playing Order—Program Play	18
Playing at Random—Random Play	19
Playing Repeatedly—Repeat Play	20
Prohibiting Disc Ejection—Child Lock	20
Timer Operations	21
Setting the Timer	21
Additional Information	23
Learning More about This System	23
Troubleshooting	24
Maintenance	24
Specifications	25
Parts Index	25

Introduction

Thank you for purchasing the JVC Micro Component System.

We hope it will be a valued addition to your home, giving you years of enjoyment.

Be sure to read this instruction manual carefully before operating your new stereo system.

In it you will find all the information you need to set up and use the system.

If you have a query that is not answered by the manual, please contact your dealer.

Precautions

Installation

- Install in a place which is level, dry and neither too hot nor too cold—between 5°C and 35°C (41°F and 95°F).
- Install the System in a location with adequate ventilation to prevent internal heat buildup inside the System.



DO NOT install the System in a location near heat sources, or in a place subject to direct sunlight, excessive dust or vibration.

- Leave sufficient distance between the System and the TV.
- Keep the speakers away from the TV to avoid interference with TV.

Power sources

- When unplugging the System from the wall outlet, always pull on the plug, not the AC power cord.



DO NOT handle the AC power cord with wet hands.

Moisture condensation

Moisture may condense on the lenses inside the System in the following cases:

- After starting to heat the room
- In a damp room
- If the System is brought directly from a cold to a warm place

Should this occur, the System may malfunction. In this case, leave the System turned on for a few hours until the moisture evaporates, unplug the AC power cord, then plug it in again.

Internal heat

- A cooling fan is mounted on the rear panel to prevent heat buildup inside the main unit (see page G-2).



For safety, observe the following carefully:

- Make sure there is good ventilation around the main unit. Poor ventilation could overheat and damage the System.
- DO NOT block the cooling fan and the ventilation openings or holes. If they are blocked by a newspaper or cloth, etc., the heat may not be able to get out.

Others

- Should any metallic object or liquid fall into the System, unplug the AC power cord and consult your dealer before operating any further.



DO NOT disassemble the System since there are no user serviceable parts inside.

- If you are not going to operate the System for an extended period of time, unplug the AC power cord from the wall outlet.

If anything goes wrong, unplug the AC power cord and consult your dealer.



How to Read This Manual ●●●●●

To make this manual as simple and easy-to-understand as possible, we have adapted the following methods:

- Button and control operations are explained as listed in the table below. In this manual, the operations using the remote control is mainly explained; however, you can use the buttons and controls on the main unit if they have the same (or similar) name and marks.
- **Some related tips and notes are explained later in the sections “Learning More about This System” and “Troubleshooting,” but not in the same section explaining the operations.** If you want to know more about the functions, or if you have a doubt about the functions, go to these sections and you will find the answers.

	Indicates that you press the button briefly .
	Indicates that you press the button briefly and repeatedly until an option you want is selected.
	Indicates that you press one of the buttons.
	Indicates that you press and hold the button for specified seconds. <ul style="list-style-type: none"> • The number inside the arrow indicates the period of press (in this example, 2 seconds). • If no number is inside the arrow, press and hold until the entire procedure is complete or until you get a result you want.
	Indicates that you turn the control toward the specified direction(s).
	Indicates that this operation is only possible using the remote control.
	Indicates that this operation is only possible using the buttons and controls on the main unit.

Getting Started

Step 1: Unpack the package and check the accessories.



Step 1: Unpack

After unpacking, check to be sure that you have all the following items. The number in parentheses indicates the quantity of each piece supplied.

- FM antenna (1)
- AM loop antenna (1)
- Remote control (1)
- Batteries (2)

If any item is missing, consult your dealer immediately.

Step 2: Prepare the Remote Control

Insert the batteries into the remote control by matching the polarity (+ and -) correctly.

Step 2: Prepare the remote control.

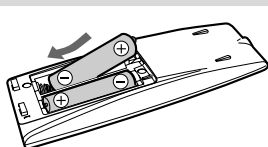

1

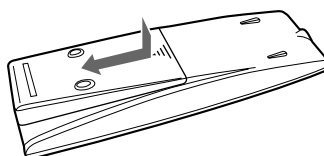

2

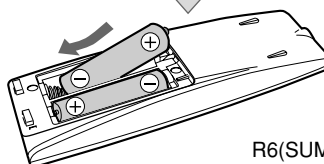

R6(SUM-3)/AA(15F)

3

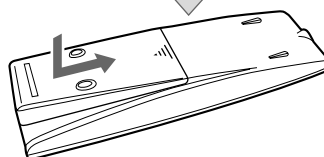

Step 3: Hook up the components such as AM/FM antennas, speakers, etc. (see pages 5 to 7).

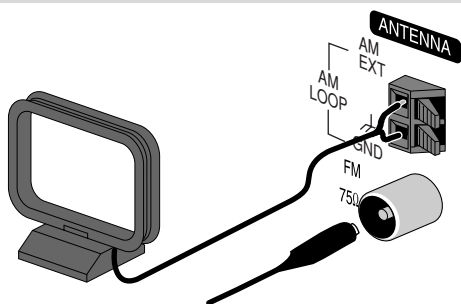

Finally plug the AC power cord.
Now you can operate the System.



- DO NOT use an old battery together with a new one.
- DO NOT use different types of batteries together.
- DO NOT expose batteries to heat or flame.
- DO NOT leave the batteries in the battery compartment when you are not going to use the remote control for an extended period of time. Otherwise, the remote control will be damaged from battery leakage.

Step 3: Hook Up

If you need more detailed information, see page 7.

For more detailed information on connecting external equipment, see pages 13 and 14.

Illustrations of the input/output terminals below are typical examples. When you connect other components, refer also to their manuals since the terminal names actually printed on the rear may vary.

Turn the power off to all components before connections.

For better FM/AM reception

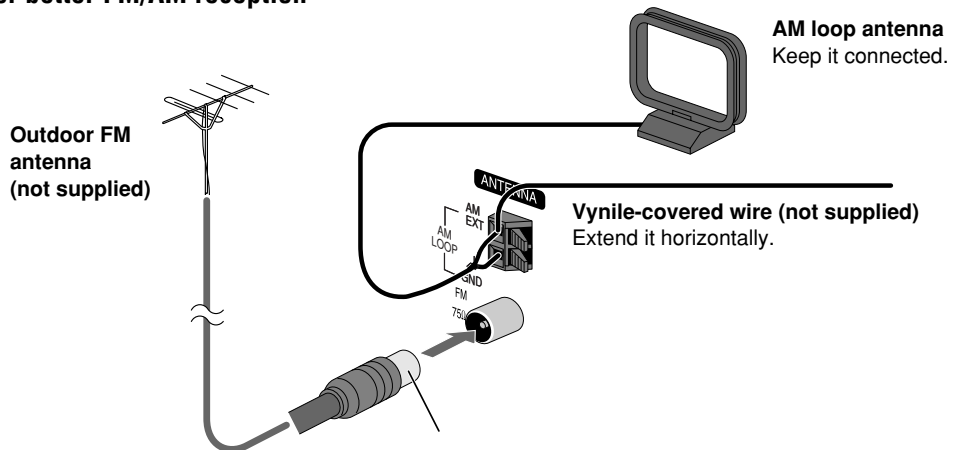

Disconnect the supplied FM antenna, and connect to an outdoor FM antenna using a 75 Ω wire with coaxial type connector.

To a wall outlet
Plug the AC power cord only after all connections are complete.

FM antenna (supplied)

Extend it so that you can obtain the best reception.

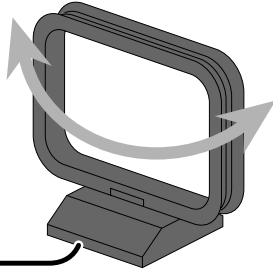

AM loop antenna (supplied)
Turn it until the best reception is obtained.

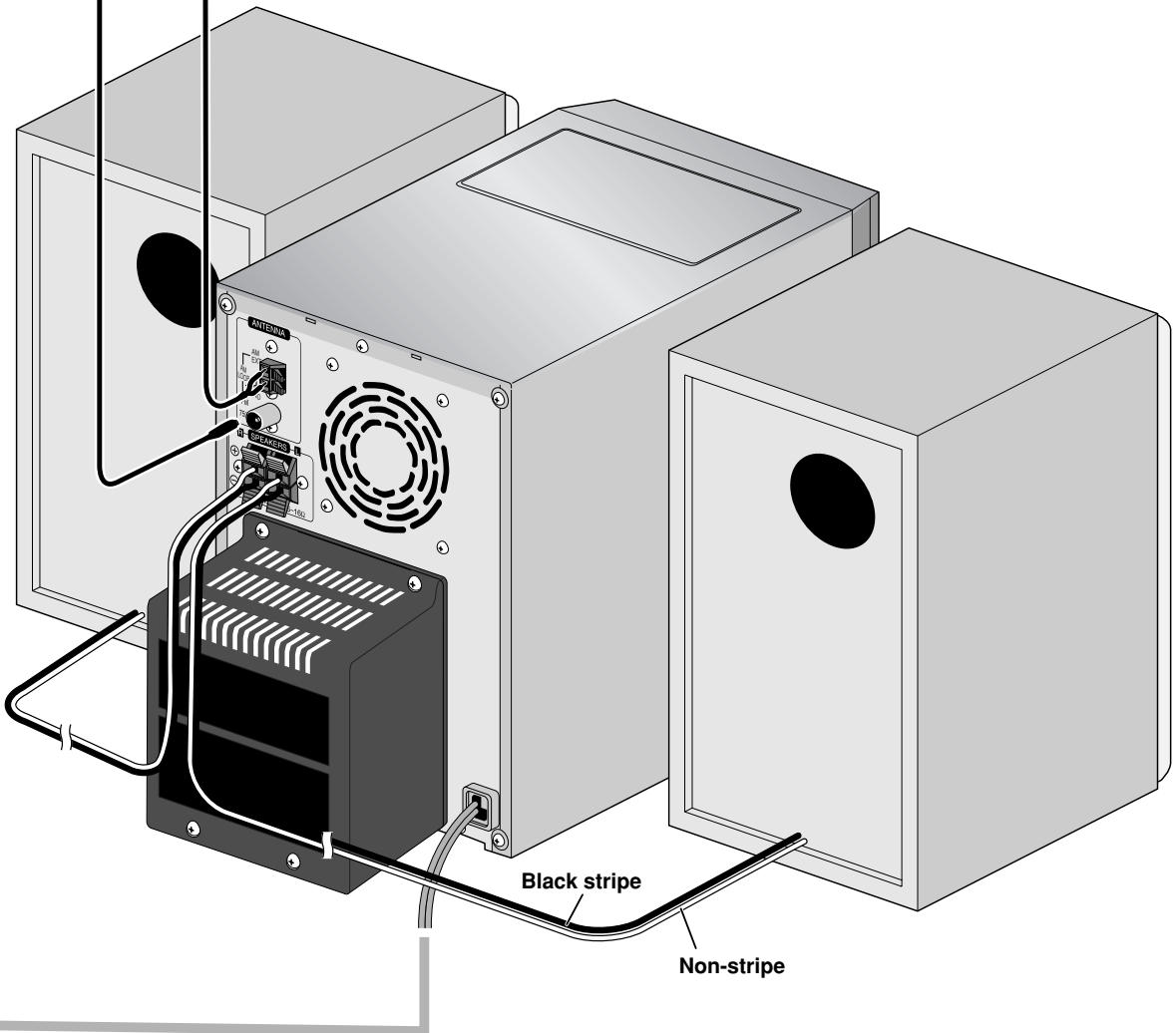



To assemble and connect the AM loop antenna

To assemble the AM loop antenna

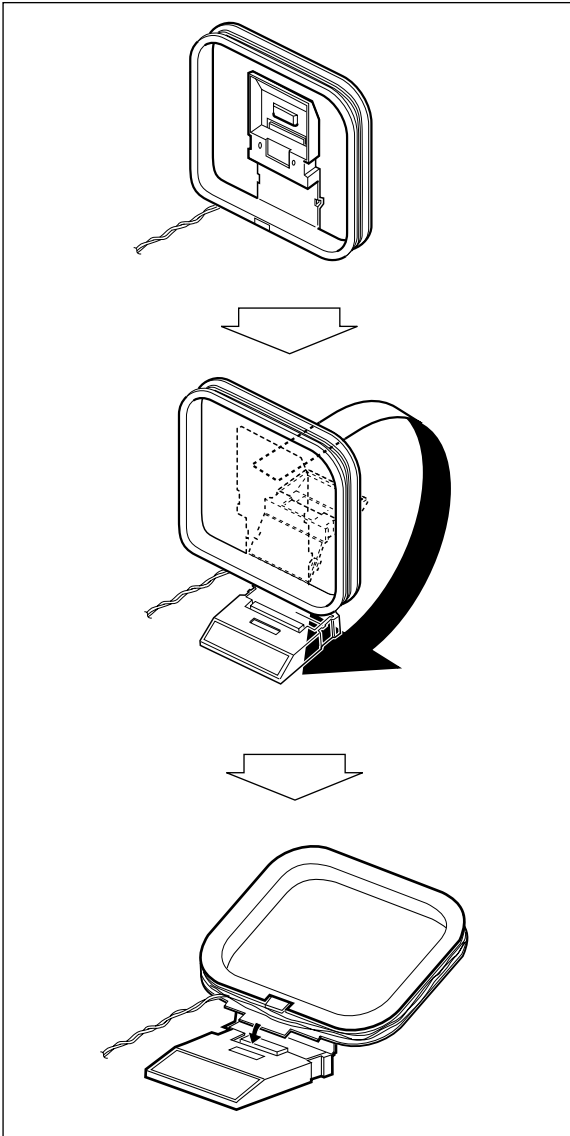

To connect the AM loop antenna

Make sure to connect the wire correctly.

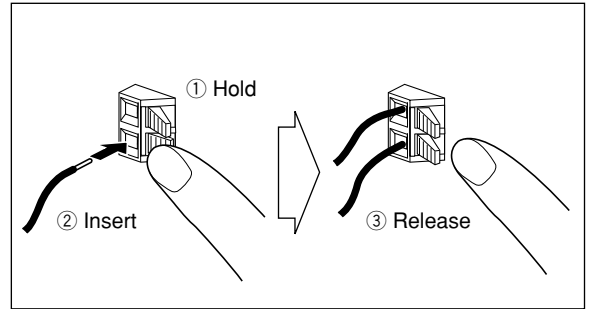

- If the AM loop antenna wire or speaker cords are covered with vinyl, remove the vinyl to expose the tip of the antenna by twisting the vinyl.
- Make sure the antenna conductors do not touch any other terminals, connecting cords and power cord. Also, keep the antennas away from metallic parts of the System, connecting cords, and the AC power cord. This could cause poor reception.

To connect the speaker cords

Make sure the both speakers are connected correctly and firmly.

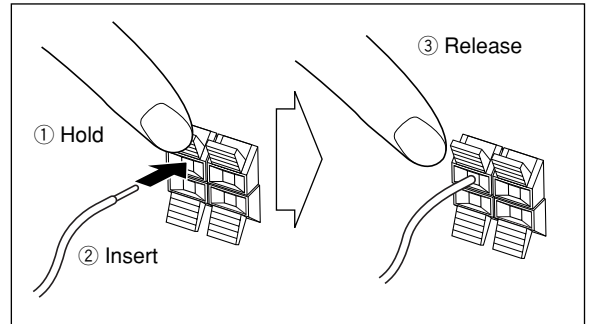

When connecting the speaker cords, match the polarity of the speaker terminals: The cord with black stripe to (-), the cord without stripe to (+).



- DO NOT connect more than one speaker to each terminal.
- DO NOT allow the conductor of the speaker cords to be in touch with the metallic parts of the System.

Before Operating the System

The indications on the display teach you a lot of things while you are operating the System. Before operating the System, be familiar with when and how the indicator illuminates on the display.

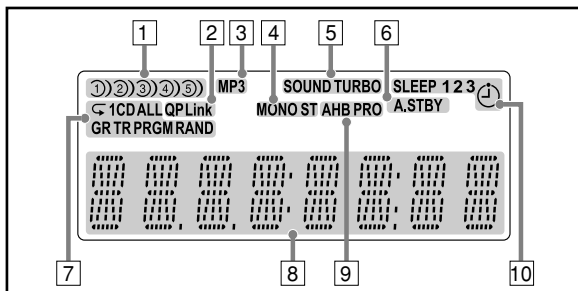

Indications on the main display

• While listening to radio:

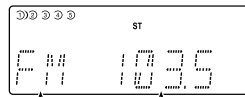

Band Frequency

• While selecting USB:



Source name

• While playing a CD:

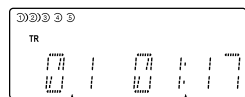

Track number Elapsed playing time

• While selecting AUX:

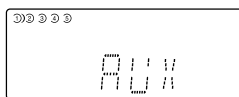

• While playing an MP3*:

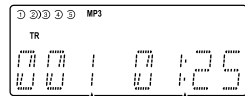

Current track number Elapsed playing time

• While disc play is stopped:

When RESUME is ON, RESUME is shown on the display.

CD:

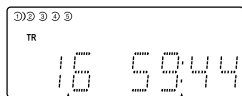

Total track number Total playing time

MP3:

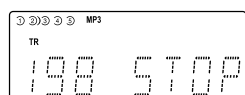

Total track number

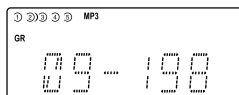

Total group number Total track number

* When you start playing an MP3 disc, the group number, track number, track name, (and ID3 Tag) will be shown before the elapsed playing time appears.

1 Disc tray indicators

- 1–5: Disc tray number
- ○ : Tray indicator
 - Lights when the disc is detected.
 - Blinking while playing back a disc.
 - Goes off when there is no disc in the tray.
- ○ : Shows the current disc.

2 QP Link Indicator

- Lights when QP Link is activated.

3 MP3 indicator

- Lights when an MP3 disc is detected.

4 FM reception indicators

- MONO: Lights while the FM monaural mode is activated.
- ST (stereo): Lights while an FM stereo station with sufficient signal strength is tuned in.

5 SOUND TURBO indicator

- Lights when the SOUND TURBO is activated (see page 15).

6 A.STBY(Auto Standby) indicator

- Lights when Auto Standby is activated.
- Flashes when disc playback stops with Auto Standby activated.

7 Play mode indicators

- RAND (random): Lights when Random Play mode is activated.
- PRGM (program): Lights when Program Play mode is activated.
- ↺ : Lights when Repeat mode is activated.
 - 1: Repeats the one track.
 - CD: Repeats the one disc
 - ALL: Repeats all the discs.
 - GR: Repeats all the tracks in the selected group.

8 Main display

9 AHB PRO (Active Hyper Bass Pro) indicator

- Lights when the AHB PRO is activated.

10 Timer indicators

- ⌚ : Lights when Daily Timer stands by; flashes while working.
- 1/2/3: Lights when a Daily Timer (1, 2, or 3) stands by; flashes while setting or working.
- SLEEP: Lights when the Sleep Timer is activated.

Daily Operations—Playback

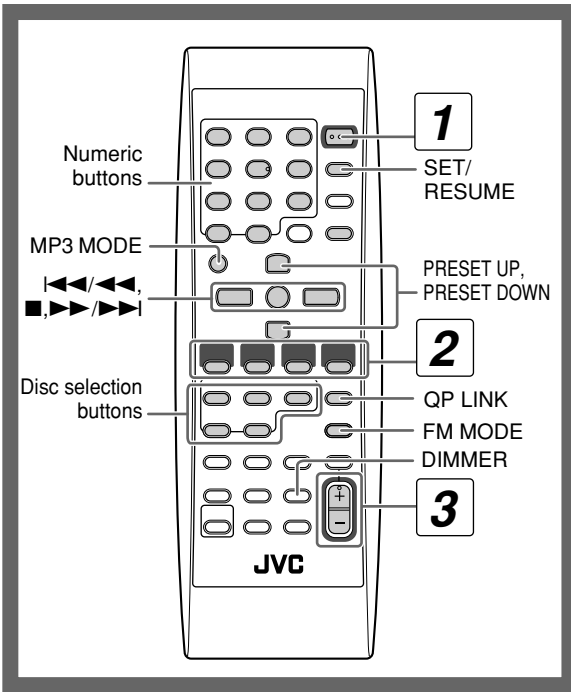

1 Turn on the power.

The STANDBY lamp on the main unit turns off.

- Without pressing STANDBY/ON ϕ/I , the System turns on by pressing one of the source selecting buttons in the next step.

2 Select the source.

Playback automatically starts if the selected source is ready to start.

- If you press AUX or USB, start playback source on the external component.

3 Adjust the volume.

4 Operate the target source as explained later.

To turn off (stand by) the System

STANDBY/ON

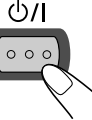

The STANDBY lamp on the main unit lights up.

- A small amount of power is always consumed even while on standby.

To turn off the clock indication to save the power



While the System is turned off...

DIMMER



- Press the button again, to display the clock indication.

For private listening

Connect a pair of headphones to the PHONES jack on the main unit. The sound will no longer come out of the speakers. Be sure to turn down the volume before connecting or putting the headphones.

- Disconnecting the headphones will activate the speakers again.

DO NOT turn off (stand by) the System with the volume set to an extremely high level; otherwise, the sudden blast of sound can damage your hearing, speakers and/or headphones when you turn on the System or start playback.

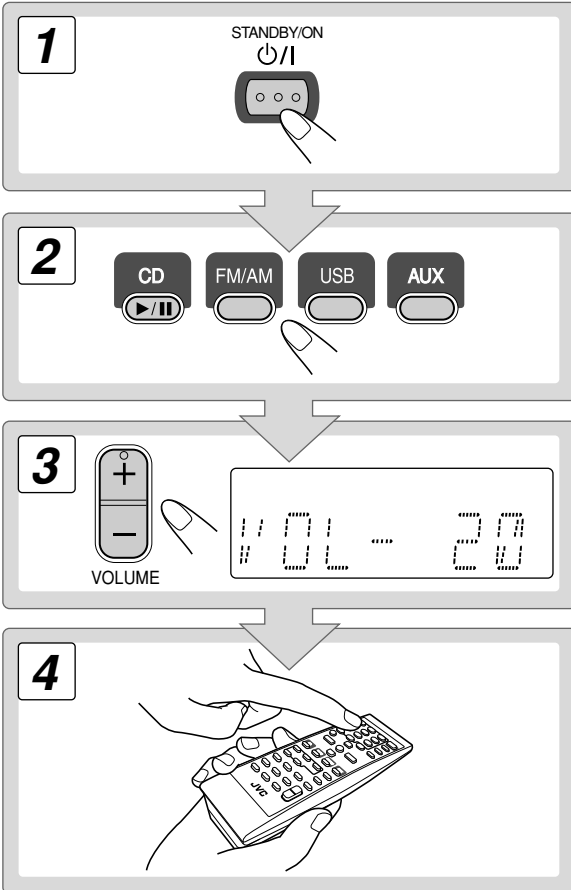

Listening to the Radio

To select the band (FM or AM)



To tune in to a station

While FM or AM is selected...

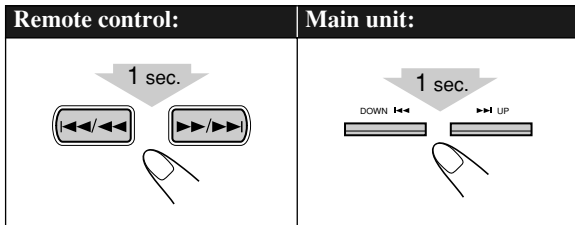

Frequency starts changing on the display.

When a station (frequency) with sufficient signal strength is tuned in, the frequency stops changing.

- When you repeatedly press the button, the frequency changes step by step.

To stop searching manually, press either button.

If the received FM station is hard to listen

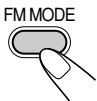

The MONO indicator lights on the display. Reception will improve though stereo effect is lost—Monaural reception mode.

To restore the stereo effect, press the button again (the MONO indicator goes off).

To preset the stations



You can preset 30 FM and 15 AM stations.

- 1 Tune in to a station you want to preset.
- 2 Activate the preset number entry mode.

SET/RESUME

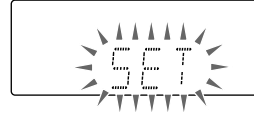

- Finish the following process while the indication on the display is flashing.

- 3 Select a preset number for the station you store.

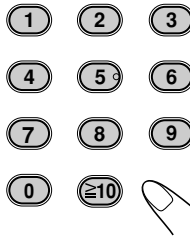

Examples:

To select preset number 5, press 5.

To select preset number 15, press $\geq 10 \rightarrow 1 \rightarrow 5$.

To select preset number 30, press $\geq 10 \rightarrow 3 \rightarrow 0$.

- You can also use the PRESET UP/PRESET DOWN buttons.

- 4 Store the station.

SET/RESUME



- If you preset a station set to MONO, the station is stored with the MONO setting.

To tune in to a preset station



1 Select a band (FM or AM).



2 Select a preset number for the station you store.

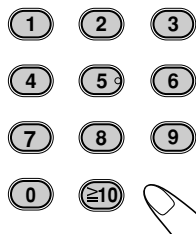

• You can also use the PRESET UP or PRESET DOWN.

Playing Back a Disc

This System can play back the following discs—regular CD and CD-R/CD-RW (recorded either in the audio CD or MP3 format).

Disc Type	Mark (logo)
Audio CD	
CD-R	
CD-RW	

• Caution for DualDisc playback

The Non-DVD side of a “DualDisc” does not comply with the “Compact Disc Digital Audio” standard. Therefore, the use of Non-DVD side of a DualDisc on this product may not be recommended.

To insert a disc



You can insert discs while playing another source.

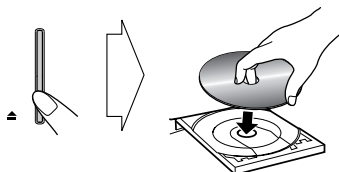

To close the disc tray, press the same again.

- When the current disc tray is open, pressing CD closes the tray and the playback starts.
- When you press for the next tray you want to place another disc onto, the first disc tray automatically closes and then the next tray comes out.

To select a disc to be played back

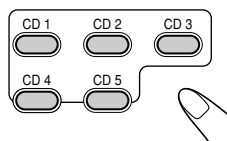

• The same operation can be carried out using CD1 to CD5 on the system.

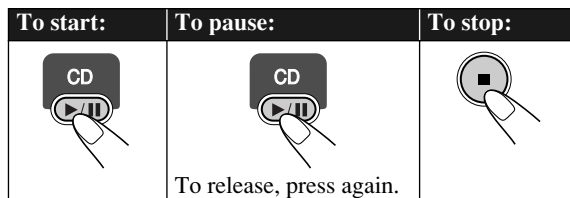

To select a track/group*

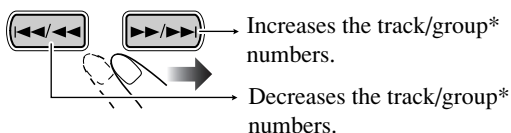

* For details about the group selection, see “For MP3 playback” on page 12.

To locate a particular portion

While playing a disc, press and hold until the portion you want is reached.

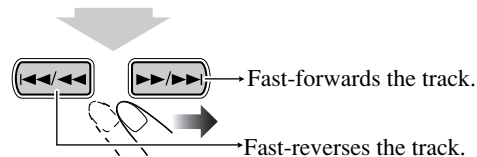

* No sound is played during this operation on MP3 discs.

To locate a track directly and start play

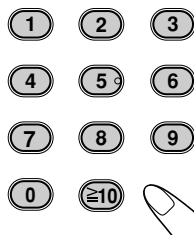

Examples:

To select track number 5, press 5.

To select track number 15, press $\geq 10 \rightarrow 1 \rightarrow 5$.

To select track number 30, press $\geq 10 \rightarrow 3 \rightarrow 0$.

(For MP3 discs with 100 or more tracks)

To select track number 125, press ≥ 10 twice $\rightarrow 1 \rightarrow 2 \rightarrow 5$.

* For up to 99 tracks, you can press ≥ 10 twice to turn to the condition before ≥ 10 is pressed.

Resume Play for Audio CD/MP3

If you press ■ during playback, the position of the track where you stopped playback will be memorized by the unit.

By pressing CD ►/||, you can start playback again from the point where you stopped it.

To activate/cancel resume play



When the source is a CD...

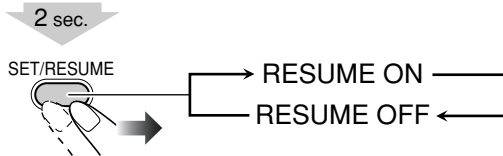

memo

- Changing the disc by pressing the disc selection buttons will erase the track number for resume play.
- To play back from the first track while resume play is activated, press ■ twice during playback then press CD ►/||.

For MP3 playback

According to the MP3 playback mode, ◀◀◀/◀◀◀/▶▶▶/▶▶▶ or number buttons work for the group selection or the track selection.

Examples:

When the MP3 play back mode is "GROUP."

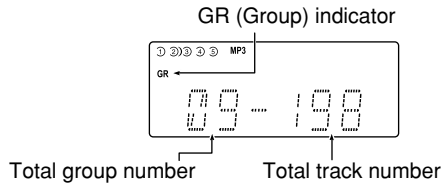

You can change the MP3 playback mode by pressing MP3 MODE.

- Each time you press the button, the MP3 playback mode changes as follows:

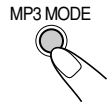

TRACK ↔ GROUP

TRACK: ◀◀◀/◀◀◀, ▶▶▶/▶▶▶, and number buttons work for the track selection of the MP3 discs.

GROUP: ◀◀◀/◀◀◀, ▶▶▶/▶▶▶, and number buttons work for the group selection of the MP3 discs.
Number buttons works for selecting the track number within the group.

MP3 groups/tracks configuration

This System plays back MP3 tracks as follows.

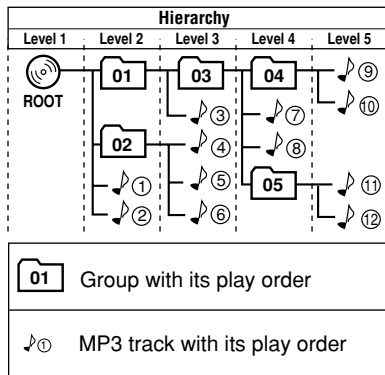

Playing Back from the PC

This System is equipped with a USB terminal on the front panel of the main unit. You can connect your PC to this terminal and enjoy sound reproduced through your PC. When you connect your PC for the first time, follow the procedure below.

- Remember you cannot send any signal or data to your PC from this System.

How to install the USB drivers

1 Turn on your PC and start running Windows® 98, Windows® 98SE, Windows® Me, Windows® 2000, or Windows® XP.

- If the PC has been turned on, quit all the applications now running.

2 Select USB as the source.

3 Set the volume to minimum.

4 Connect the System to the PC using a USB cable (not supplied).

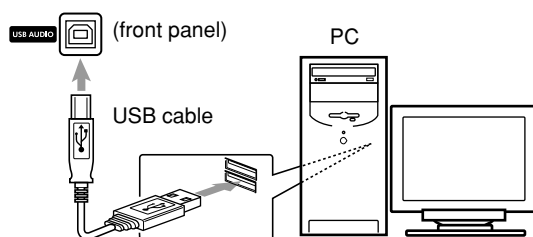

- Use “USB series A plug to B plug” cable when connecting.

IMPORTANT

- Always set volume to “VOL-MIN” when connecting or disconnecting the other equipment.

5 The USB drivers are installed automatically.

To play back sounds on the PC

Press USB, then start playback from PC.

Refer to the manuals supplied with the sound reproduction application installed in the PC.

*Microsoft®, Windows® 98, Windows® 98SE, Windows® Me, Windows® 2000 and Windows® XP are registered trademarks of Microsoft corporation.

Playing Back from other equipment

To connect other equipment

By using a stereo mini plug cord (not supplied), you can connect equipment with analog audio output jacks such as a Digital Audio Player, or a TV, etc.

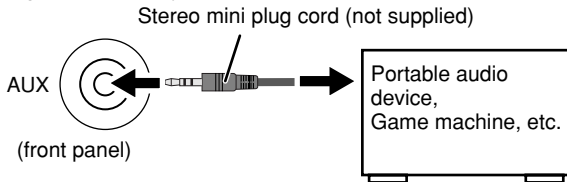

If the audio output on the other equipment is not stereo mini plug type,

Use a plug adapter to convert the stereo mini plug to the corresponding plug of the audio output.

Refer to the manuals supplied with the other equipment.

IMPORTANT

- Always set volume to “VOL-MIN” when connecting or disconnecting the other equipment.

To adjust the sound input level from other equipment

You can adjust the sound input level from the connected equipment, if the incoming signal is too small or too large.

- 1 Select AUX for the source.
- 2 Adjust the input level.

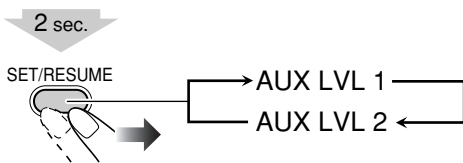

AUX LVL 1: Ordinary input level (factory setting).

Suitable for equipment with low output level (such as a portable audio device).

AUX LVL 2: Decreased input level.

Suitable for equipment with high output level (such as a DVD player).

memo

- If you feel that the output level from the external equipment is high, select AUX LVL2.

Quick Portable Link (QP Link)

If you connect other equipment such as a digital audio player to the AUX terminal and play it back, the source automatically changes to AUX.

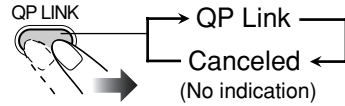

The QP Link indicator is lit while QP Link is activated.

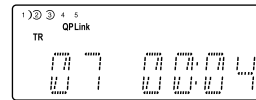

When QP Link is activated...

- If an audio input is received at AUX when the System is turned on, the source automatically switches to AUX.
- If an audio input is received at AUX when the System is in standby mode, the system automatically turns on and plays the audio.
- You cannot change the source while audio input is being received at AUX.

If you press another source button, the QP Link indicator blinks several times.

memo

- While playback is going on the portable audio device, QP Link may turn the System on even if the Sleep Timer turn the System to standby or if you turn the System to standby. In this case, deactivate QP Link or stop playback on the device connected to the AUX jack.
- If the audio input received at AUX is small, the source may not switch to AUX.
- The source may not switch to AUX depending on the content of the music.
- It takes a second or two for the source to switch to AUX after another equipment such as a digital audio player is started and sound is output. This is due to the System detecting the signal from the equipment.
- QP Link does not work, if the clock indication is turned off at standby.

Daily Operations—Sound & Other Adjustments

Remote control

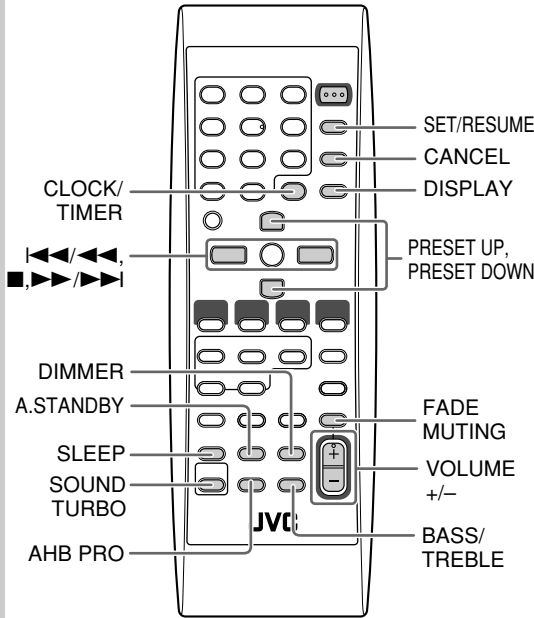

Main unit

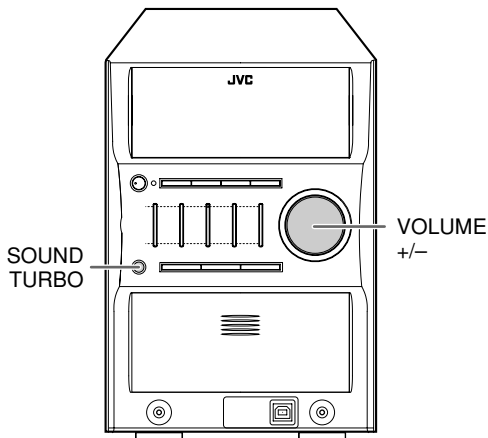

Adjusting the Volume

You can adjust the volume level from level 0 (VOL-MIN) to level 31 (VOL-MAX).

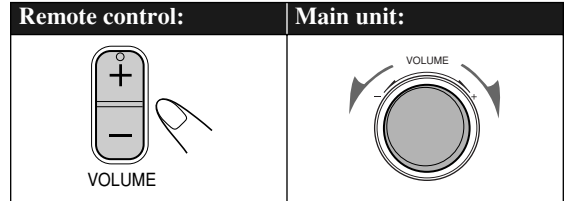

To drop the volume in a moment



To restore the volume, press again, or adjust the volume level.

Adjusting the Sound

To emphasize the sound—SOUND TURBO

This function emphasizes the sound.

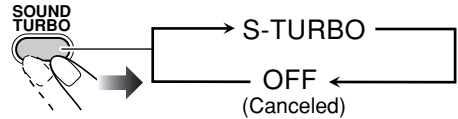

To reinforce the bass sound—AHB PRO

You can reinforce the bass sound to maintain rich, full bass at low volume.

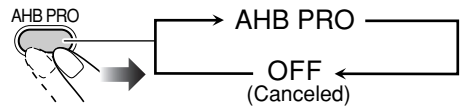

To adjust the tone—BASS/TREBLE

You can adjust the bass and treble level from 0 to +5.

To adjust the bass



To adjust the treble

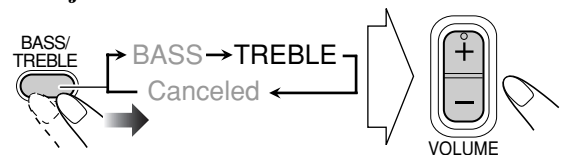

When SOUND TURBO is ON, BASS/TREBLE is disabled.

Changing the Display Brightness



You can dim the display window.

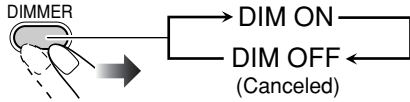

Setting the Clock



Without setting the built-in clock, you cannot use the Daily Timer (see page 21).

- To exit from the clock setting, press **CLOCK/TIMER** as required.
- To go back to the previous step, press **CANCEL**.

1 Activate the clock setting mode.

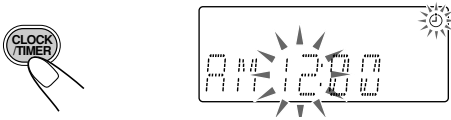

- If you have already adjusted the clock before, press the button repeatedly until the clock setting mode (see page 21) is selected.

2 Adjust the hour.

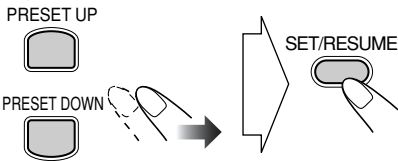

3 Adjust the minute.

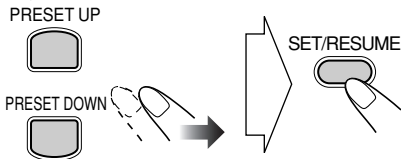

“CLOCK OK” appears and the built-in clock starts working.

To check the current time during play

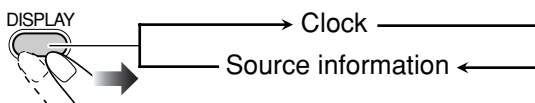

If there is a power failure

The clock loses the setting and is reset to “AM 12:00.” You need to set the clock again.



Turning Off the Power Automatically



To turn off the System after playback is over—Auto Standby

This function works only when the source is CD.

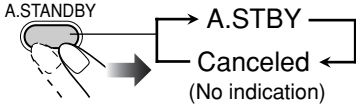

When Auto Standby is in use, the A.STBY indicator lights on the display.

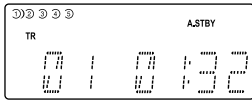

When the disc playback stops, the A.STBY indicator starts flashing.

If no disc operation is done for about 3 minutes while the indicator is flashing, the System turns off (stands by) automatically.

To turn off the System after a certain period of time—Sleep Timer

1 Specify the time (in minutes).

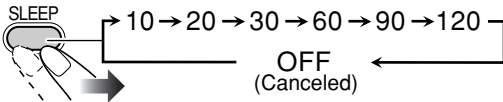

2 Wait until the set time goes off.

To check the time remaining until the shut-off time

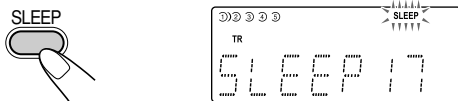

- If you press the button repeatedly, you can change the shut-off time.

Advanced Disc Operations

Remote control

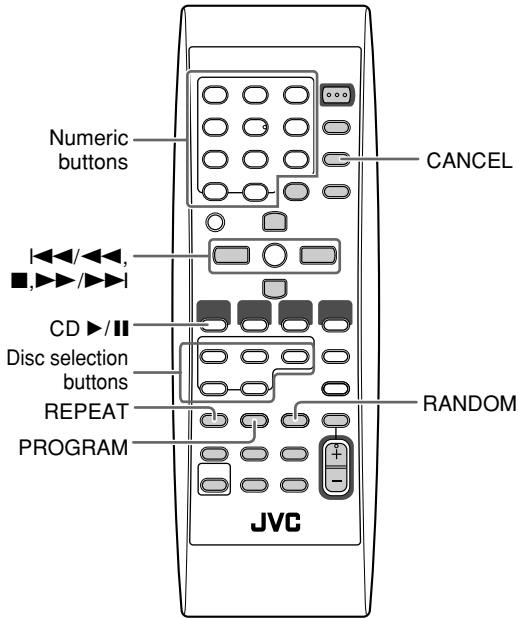

Main unit

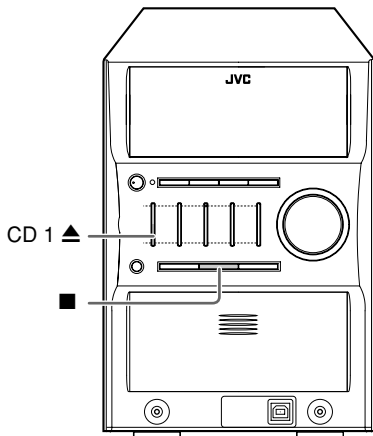

Programming the Playing Order

Program Play

You can arrange the playing order of the tracks (up to 32) before you start playback.

- You cannot enjoy MP3 discs for program play.
- You can repeat all the programmed tracks by pressing REPEAT.

1 Before starting playback, press PROGRAM.

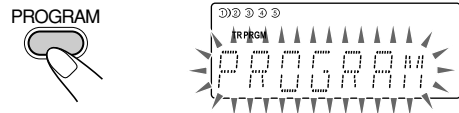

2 Select a disc by pressing CD 1-CD 5.

3 Select tracks you want for Program Play.

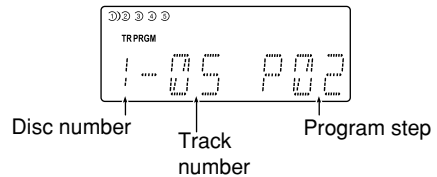

Examples:

- ① ② ③ To select track number 5, press 5.
- ④ ⑤ ⑥ To select track number 15, press $\geq 10 \rightarrow 1 \rightarrow 5$.
- ⑦ ⑧ ⑨ To select track number 30, press $\geq 10 \rightarrow 3 \rightarrow 0$.
- ⑩ ≥ 10



4 Repeat steps 2 and 3 to program the other tracks.

- To select a track from the same disc, repeat step 3.

5 Start playback.

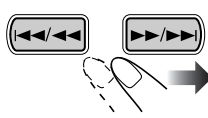

The tracks you have selected are played back in the order you have programmed.

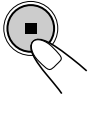
To skip a track:	To pause:	To stop:
	 To release, press again.	

- Tracks cannot be selected with the Numeric buttons during Program Play.

To check the programmed contents

While the PRGM indicator is shown on the display and before playback...

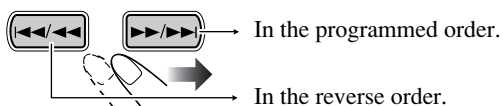

To modify the program

While the PRGM indicator is shown on the display and before playback...

To erase the last step:	To erase the entire program:
To add steps in the program: Repeat steps 2 and 3 on page 18.	

To exit from Program Play

While the PRGM indicator is shown on the display...



Pressing ■ also cancels Program Play.

- During the PRGM indicator is shown on the display, you cannot open the disc trays.

Playing at Random—Random Play

You can play back all the tracks on the selected disc at random.

- You can repeat the current disc by pressing REPEAT.

- 1 Select a disc by pressing CD 1 – CD 5.
- 2 Press RANDOM.



Playback starts in random order.

Random Play ends when all tracks are played.

To skip a track:	To pause:	To stop:
	To release, press again.	

- Tracks cannot be selected with the Numeric buttons during Random Play.

To exit from Random Play

While the RAND indicator is shown on the display...



Playing Repeatedly—Repeat Play

You can repeat playback.

For CD/MP3 (TRACK mode):

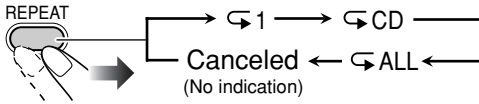

For MP3 (GROUP mode):

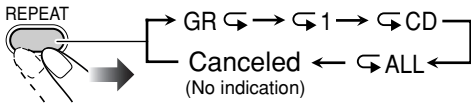

During Program Play:

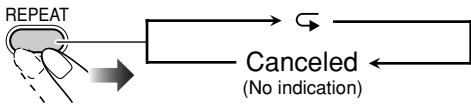

During Random Play:

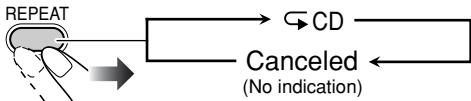

Prohibiting Disc Ejection—Child Lock

You can lock the disc trays so that no one can eject the loaded discs.



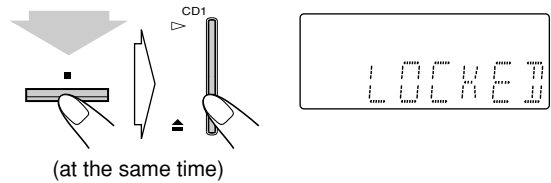

- This is possible while the System is on standby.

While the disc trays are closed...



- Only CD 1 ▲ can work for this function.

To cancel the prohibition, repeat the same procedure. “UNLOCKED” appears on the display.

	Repeats the current track.
	Repeats all the tracks on the current disc. (Selectable in Normal play and Random play)
	Repeats all the tracks in the current group (for MP3 playback mode in “GROUP” only).
	Repeats all the discs.
	Repeats the program.

Timer Operations

Remote control

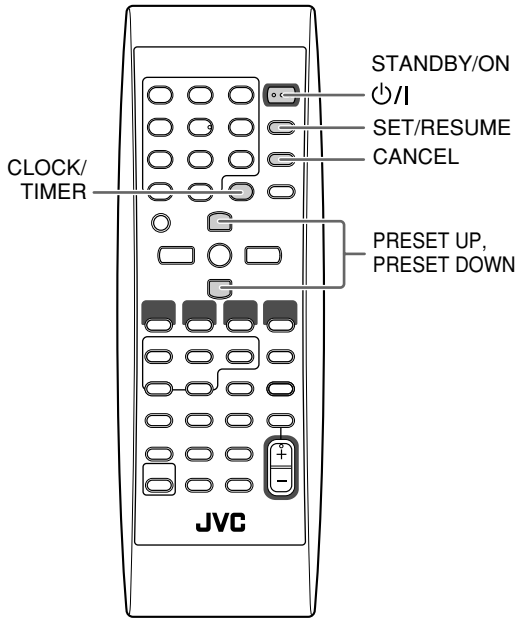

Setting the Timer

- Using Daily Timer, you can wake up with music, etc.
- You can store three Daily Timer settings; however, you can activate only one of Daily Timers at the same time.
 - To exit from the timer setting, press CLOCK/TIMER as required.
 - To correct a misentry during the process, press CANCEL. You can return to the previous step.

How Daily Timer actually works

Once the Daily Timer has been set, the timer (⌚) indicator and timer number indicator (1, 2, or 3) are lit on the display. Daily Timer is activated at the same time everyday until the timer is turned off manually or another Daily Timer is activated.

When the on-time comes

The System turns on, tunes in to the selected station or start playing the selected disc, and sets the volume level to the preset level.

- If “P ---” is selected, the last tuned station is selected.
- If “VOL ---” is selected, the last specified value is selected.
- While Daily Timer is working, the timer (⌚) and timer number indicators (1, 2, or 3) flash on the display.
- The timer setting remains in memory until you change it.
- Without canceling the Daily Timer, you can change the source or adjust the volume after Daily Timer starts playback.

1 Select one of the timer setting modes you want to set—Daily 1 Timer, Daily 2 Timer, or Daily 3 Timer.

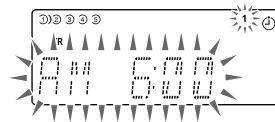
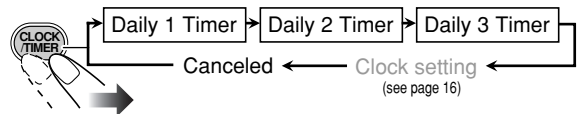

Ex.: When Daily Timer 1 setting mode is selected

2 Make the timer setting as you want.

- ① Set the hour then the minute for on-time.

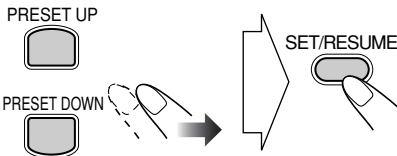

- ② Set the hour then the minute for off-time in the same manner.

- ③ Select the playback source—"TUNER FM," "TUNER AM," "DISC," or "AUX."

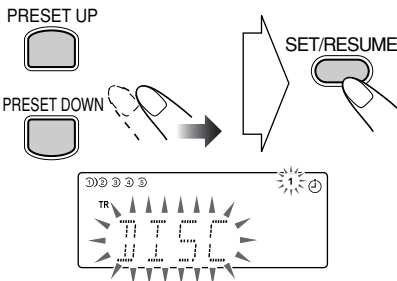

When selecting tuner: Select a preset number or "P ---" by pressing PRESET UP or PRESET DOWN, then press SET.

When selecting CD: Select a disc by pressing PRESET UP or PRESET DOWN, then press SET.

- ④ Set the volume.

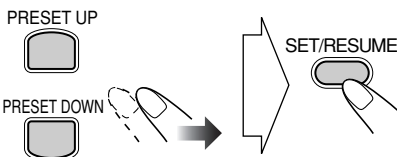

If you select "VOL --," the volume is set to the level that was set before the power was turned off.

3 Turn off the System (on standby) if you have set the timer with the System turned on.

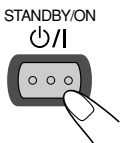

To turn off the Timer after its setting is done

Since Daily Timer is activated at the same time everyday, you may need to cancel it on some particular days.

1 Select the Timer you want to cancel.

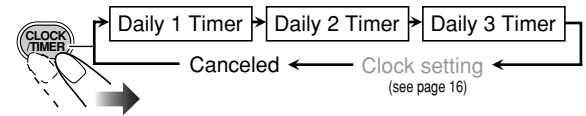

2 Turn off the selected Timer.



The number indicator corresponding to the Daily Timer is turned off.

To turn on the Timer again, repeat the above steps and press in step 2...



The number indicator corresponding to the Daily Timer lights.

Additional Information

Learning More about This System

Daily Operations—Playback (see pages 9 to 14)

Listening to the Radio:

- If you store a new station into an occupied preset number, the previously stored station in that number will be erased.
- When you unplug the AC power cord or if a power failure occurs, the preset stations will be erased in a few days. If this happens, preset the stations again.

Playing Back a Disc:

- When using an 8 cm (3⁻³/₁₆ inch) disc, place it on the inner circle of the disc tray.
- This System cannot play “packet write” discs.
- For MP3 playback...
 - MP3 discs are required a longer readout time than regular CDs. (It depends on the complexity of the group/file configuration.)
 - Some MP3 files cannot be played back and will be skipped. This result from their recording processes and conditions.
 - When making MP3 discs, use ISO 9660 Level 1 or Level 2 for the disc format.
 - This System can play back MP3 files with the extension code <.mp3> (regardless of the letter case—upper/lower).
 - Some characters or symbols will not be shown correctly on the display.
- The maximum character number shown on the display is 32 (without the extension code) for files, and 30 for ID3 tag.
- It is recommended that you make each MP3 file at a sampling rate of 44.1 kHz and at bit rate of 128 kbps.
- This System can recognize the total of 500 tracks and of 200 groups. Those exceeding the maximum number cannot be recognized.
- Playback order of MP3 tracks may be different from the one you have intended while recording. If a folder does not include MP3 tracks, they are ignored.

When discs* in more than one tray are loaded on the disc trays, they are played in sequence as follows:

Ex.: When CD 2 is selected:

CD 2 -> CD 3 -> CD 4 -> CD 5 -> CD 1 (then selects CD 2, and stops)

- * When no disc is loaded on the tray, that disc number is skipped.

You can exchange discs while playing or selecting another disc.

Quick Portable Link (QP Link)

- The system holds the On/Off status of QP Link even when the AC power cord is connected or removed.
- The source remains at AUX when you stop the other equipment such as a digital audio player.

Daily Operations—Sound & Other Adjustments (see pages 15 to 17)

Adjusting the Volume:

- Be sure to turn down the volume before connecting or putting the headphones.

Adjusting the Sound:

- This function also affects the sound through the headphones.

Setting the Clock:

- “AM12:00” will flash on the display until you set the clock.
- The clock may gain or lose 1 to 2 minutes per month. If this happens, reset the clock.

Turning the Power Automatically:

- Auto Standby cannot be canceled by the following operations.
 - Changing the display brightness.
 - Adjusting the volume.
 - Adjusting the sound.

Advanced Disc Operations (see pages 18 to 20)

Programming the Playing Order—Program Play:

- If you try to program a 33rd track, “FULL” appears on the display.
- While programming steps...
 - Your entry will be ignored if you have tried to program an item number that does not exist on the disc (for example, selecting track 14 on a disc that only has 12 tracks).

Timer Operations (see pages 21 and 22)

- When you unplug the AC power cord or if a power failure occurs, the timer will be canceled. You need to set the clock first, then the timer again.
- If you set the Sleep Timer after Daily Timer starts playing the selected source, Daily Timer is canceled.

Other

The following settings are memorized by the system for two or three days even if the AC power cord is removed. The settings are reset to factory default values after few days in which case you must set them again.

Preset stations, volume, BASS/TREBLE, AHB PRO, SOUNDN TURBO, AUX LEVEL, QP Link, and timer.

To remove the speaker grilles

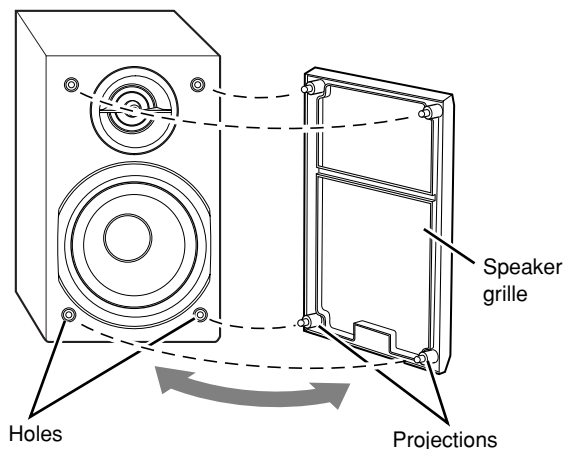

Troubleshooting

If you are having a problem with your System, check this list for a possible solution before calling for service.

General:

Adjustments or settings are suddenly canceled before you finish.

⇒ There is a time limit. Repeat the procedure again.

Operations are disabled.

⇒ The built-in microprocessor may malfunction due to external electrical interference. Unplug the AC power cord and then plug it back in.

Unable to operate the System from the remote control.

⇒ The path between the remote control and the remote sensor on the System is blocked.

⇒ Point it at the remote sensor on the front panel.

⇒ Signals cannot reach the remote sensor.

More closer to the System.

⇒ The batteries are exhausted.

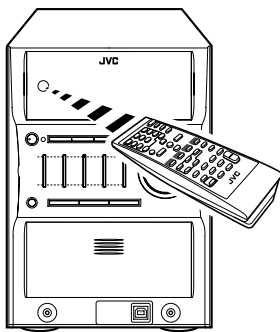

No sound is heard from the speakers.

⇒ Speaker connections are incorrect or loose (see page 7).

⇒ Headphones are connected (see page 9).

System does not turn off.

⇒ QP Link is active (see page 14).

Radio Operations:

Hard to listen to broadcasts because of noise (see pages 4 to 7).

⇒ Antennas connections are incorrect or loose.

⇒ The AM loop antenna is too close to the System.

⇒ The FM antenna is not properly extended and positioned.

Disc Operations:

The disc does not play.

⇒ The disc is placed upside down. Place the disc with the label side up.

The disc sound is discontinuous.

⇒ The disc is scratched or dirty.

The disc tray does not open or close.

⇒ The AC power cord is not plugged in.

⇒ Child Lock is in use (see page 20).

Timer Operations:

Daily Timer does not work.

⇒ The System has been turned on when the on-time comes.

Timer starts working only when the System is turned off.

Maintenance

To get the best performance of the System, keep your discs, and mechanism clean.

Handling discs

- When removing the disc from its case, hold it at the edge while pressing the center hole lightly.
- Do not touch the shiny surface of the disc, or bend the disc.
- Put the disc back in its case after use to prevent warping.
- Be careful not to scratch the surface of the disc.
- Avoid exposure to direct sunlight, temperature extremes, and moisture.

To clean the disc:

Wipe the disc with a soft cloth in a straight line from center to edge.

Cleaning the System

- Stains should be wiped off with a soft cloth. If the System is heavily stained, wipe it with a cloth soaked in water-diluted neutral detergent and wrung well, then wipe clean with a dry cloth.
- Since the System may deteriorate in quality, it become damaged or get its paint peeled off, be careful about the following:
 - DO NOT wipe it with a hard cloth.
 - DO NOT wipe it strongly.
 - DO NOT wipe it with thinner or benzine.
 - DO NOT apply any volatile substance such as insecticides to it.
 - DO NOT allow any rubber or plastic to remain in contact for a long time.

Specifications

Amplifier section

Output Power:

120 W per channel, min. RMS, driven into 6 Ω at 1 kHz with no more than 10% total harmonic distortion.

Speakers Impedance: 6 Ω – 16 Ω

Audio Input AUX

Input sensitivity/Impedance:

LEVEL1: 150 mV/47 kΩ

LEVEL2: 500 mV/47 kΩ

USB: USB Ver. 1.1

Tuner section

FM tuning range: 87.5 MHz – 108.0 MHz

AM tuning range: 530 kHz – 1 710 kHz

CD player section

Dynamic range: 85 dB

Signal-to-noise ratio: 85 dB

Wow and flutter: Immeasurable

General

Power requirement: AC 120 V ~, 60 Hz

Power consumption: 155 W (at operation)

20 W (at standby)

0.8 W (at on standby and Display off)

Dimensions (approx.): 175 mm × 246 mm × 415 mm
(6-15/16" × 9-11/16" × 16-3/8")
(W/H/D)

Mass (approx.): 7.4 kg (16.4 lbs)

Speakers

Type: 2-way Bass reflex

Speaker units: Woofer: 12 cm (4") cone × 1

Tweeter: 4 cm (1-5/8") cone × 1

Impedance: 6 Ω

Dimensions (approx.): 145 mm × 246 mm × 212 mm
(5-3/4" × 9-11/16" × 8-3/8")
(W/H/D)

Mass (approx.): 2.2 kg (4.9 lbs) each

Supplied Accessories

See page 4.

Design and specification are subject to change without notice.

Parts Index

Refer to the pages to see how to use the buttons and controls.

Remote control

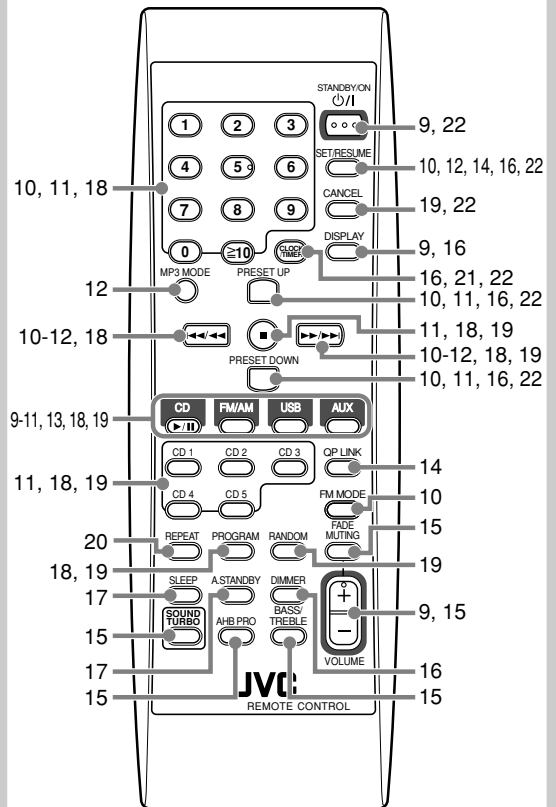

Main unit

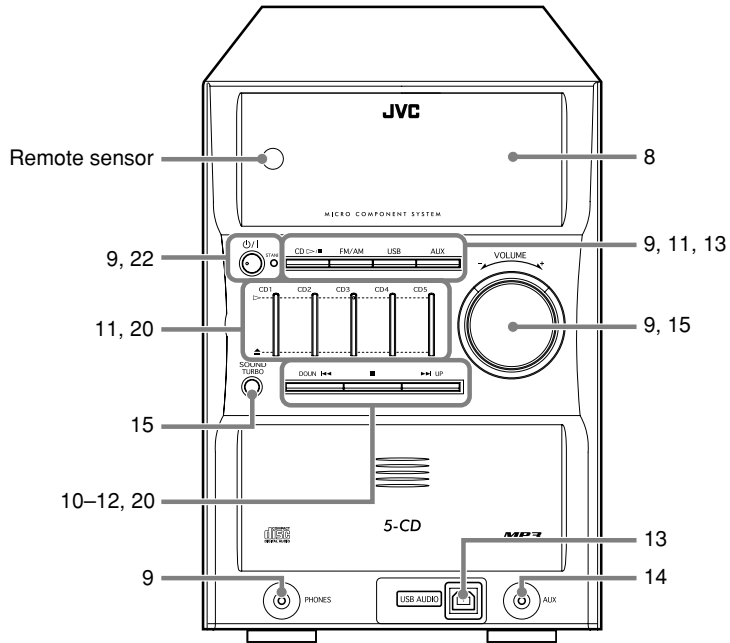

TO OUR VALUED CUSTOMER ———

THANK YOU FOR PURCHASING THIS JVC PRODUCT.
WE WANT TO HELP YOU ACHIEVE A PERFECT EXPERIENCE.

**NEED HELP ON HOW TO HOOK UP?
NEED ASSISTANCE ON HOW TO OPERATE?
NEED TO LOCATE A JVC SERVICE CENTER?
LIKE TO PURCHASE ACCESSORIES?**

JVC[®] IS HERE TO HELP!
TOLL FREE: 1(800)252-5722
<http://www.jvc.com>

Remember to retain your Bill of Sale for Warranty Service.

————— **Do not attempt to service the product yourself** —————

Caution

To prevent electrical shock, do not open the cabinet.
There are no user serviceable parts inside.
Please refer to qualified service personnel for repairs.



LIMITED WARRANTY

AUDIO-1

JVC COMPANY OF AMERICA (JVC) warrants this product and all parts thereof, except as set forth below ONLY TO THE ORIGINAL RETAIL PURCHASER to be FREE FROM DEFECTIVE MATERIALS AND WORKMANSHIP from the date of original purchase for the period shown below. ("The Warranty Period")

PARTS	1 YR	LABOR	1 YR
-------	-------------	-------	-------------

THIS LIMITED WARRANTY IS VALID ONLY IN THE FIFTY (50) UNITED STATES, THE DISTRICT OF COLUMBIA AND IN THE COMMONWEALTH OF PUERTO RICO.

WHAT WE WILL DO:

If this product is found to be defective within the warranty period, JVC will repair or replace defective parts with new or rebuilt equivalents at no charge to the original owner. Such repair and replacement services shall be rendered by JVC during normal business hours at JVC authorized service centers. Parts used for replacement are warranted only for the remainder of the Warranty Period. All products may be brought to a JVC authorized service center on a carry-in basis. Color televisions with a screen size of 27" or greater qualify for in-home service. In such cases, a technician will come to your home and either repair the TV there or remove and return it if it cannot be repaired in your home.

WHAT YOU MUST DO FOR WARRANTY SERVICE:

Please do not return your product to the retailer
Instead, return your product to the JVC authorized service center nearest you. If shipping the product to the service center, please be sure to package it carefully, preferably in the original packaging, and include a brief description of the problem(s). Please call 1-800-252-5722 to locate the nearest JVC authorized service center. Service locations can also be obtained from our website <http://www.jvc.com>. If your product qualifies for in-home service, the service representative will require clear access to the product.

If you have any questions concerning your JVC Product, please contact our Customer Relations Department at 800-252-5722

WHAT IS NOT COVERED:

This limited warranty provided by JVC does not cover:

1. Products which have been subject to abuse, accident, alteration, modification, tampering, negligence, misuse, faulty installation, lack of reasonable care, or if repaired or serviced by anyone other than a service facility authorized by JVC to render such service, or if affixed to any attachment not provided with the products, or if the model or serial number has been altered, tampered with, defaced or removed;
2. Initial installation, installation and removal from cabinets or mounting systems.
3. Operational adjustments covered in the Owner's Manual, normal maintenance, video and audio head cleaning;
4. Damage that occurs in shipment, due to act of God, and cosmetic damage;
5. Signal reception problems and failures due to line power surge;
6. Video Pick-up Tubes/CCD Image Sensors are covered for 90 days from the date of purchase;
7. Accessories;
8. Batteries (except that Rechargeable Batteries are covered for 90 days from the date of purchase);
9. Products used for commercial purposes, including, but not limited to rental.

There are no express warranties except as listed above.

THE DURATION OF ANY IMPLIED WARRANTIES, INCLUDING THE IMPLIED WARRANTY OF MERCHANTABILITY, IS LIMITED TO THE DURATION OF THE EXPRESS WARRANTY HEREIN.

JVC SHALL NOT BE LIABLE FOR ANY LOSS OF USE OF THE PRODUCT, INCONVENIENCE, OR ANY OTHER DAMAGES, WHETHER DIRECT, INCIDENTAL OR CONSEQUENTIAL (INCLUDING, WITHOUT LIMITATION, DAMAGE TO TAPES, RECORDS OR DISCS) RESULTING FROM THE USE OF THIS PRODUCT, OR ARISING OUT OF ANY BREACH OF THIS WARRANTY. ALL EXPRESS AND IMPLIED WARRANTIES, INCLUDING THE WARRANTIES OF MERCHANTABILITY AND FITNESS FOR PARTICULAR PURPOSE, ARE LIMITED TO THE WARRANTY PERIOD SET FORTH ABOVE.

Some states do not allow the exclusion of incidental or consequential damages or limitations on how long an implied warranty lasts, so these limitations or exclusions may not apply to you. This warranty gives you specific legal rights and you may also have other rights which vary from state to state.

JVC COMPANY OF AMERICA
 DIVISION OF JVC AMERICAS CORP.
<http://www.jvc.com>

1700 Valley Road
 Wayne, NJ 07470

REFURBISHED PRODUCTS CARRY A SEPARATE WARRANTY, THIS WARRANTY DOES NOT APPLY. FOR DETAIL OF REFURBISHED PRODUCT WARRANTY, PLEASE REFER TO THE REFURBISHED PRODUCT WARRANTY INFORMATION PACKAGED WITH EACH REFURBISHED PRODUCT.

For customer use:
 Enter below the Model No. and Serial No. which is located either on the rear, bottom or side of the cabinet. Retain this information for future reference.

Model No. : _____ Serial No. : _____
 Purchase date : _____ Name of dealer : _____

JVC